

SIDE

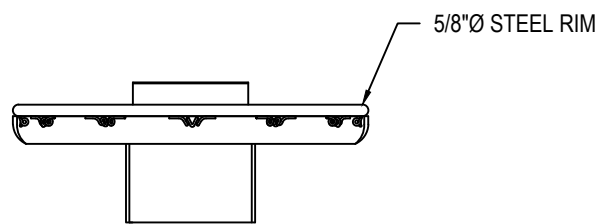

FRONT

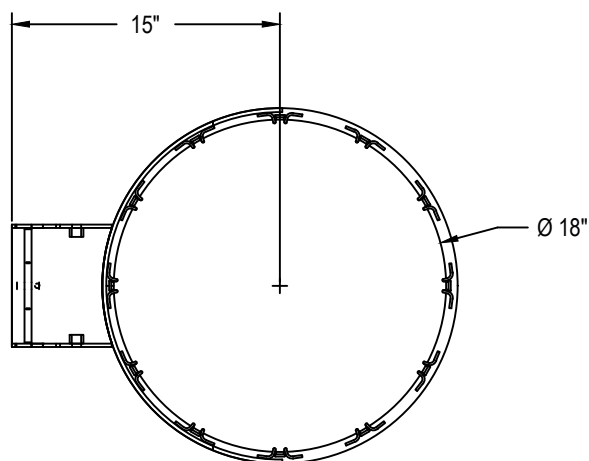

BOTTOM

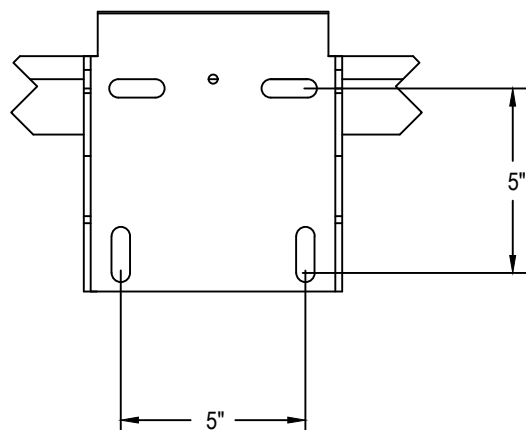

REAR

Rim shall be of a flexible type so as to absorb the player contact. Spring action shall be provided by 2 compression springs. Rim shall have a one-piece continuous wire net attachment system to accept nylon net (included). The rim shall be of an institutional quality with all structural components being no less than 3/16" thick. The ring shall be an official size 5/8" AISI 1018 cold drawn carbon steel and be supported by a 3/16" x 1 1/2" rim support that is welded around 180° of the bottom of the ring. A steel coverplate must enclose all internal mechanism. Rim shall be punched to mount on any front mount backboard, have a 90 day limited warranty and an orange powder coated finish. Mounting hardware shall be included. Installation to be completed in accordance with manufacturer's instructions. Do not scale drawings. Rim shall be made in the USA and weigh approximately 22#.



PRODUCT SPECIFICATION

BA32XL Hang Tough Breakaway